

Analysis of Cosequences of Faults in General Zero Transmission Lines of Power Supply Stations

D. A. Simonyan, A. A. Gasparyan

Abstract— Zero transmission line faults in power supply systems in large apartment houses, office blocks, offices and other structures cause voltage excursions, which are in the spotlight of this research. The phenomenon has been commented from the theoretical perspective, and emergency situations, which are likely to arise as a result of malfunction of single-phase power supply consumers, as well as the probable dangers of fire occurrences, have been revealed. We offer to install an appropriate protective device to avoid such emergency situations.

Index Terms— groundingsystem, zero transmission line, power supply line faults, circuit fault analysis, single-phase consumers, substation, control cabinet, power supply.

I. INTRODUCTION

In the power supply system general zero transmission line malfunctions, their consequences and theoretical descriptions are rarely referred to, therefore one may wonder why and how these malfunctions lead to voltage surge in large apartment houses, office blocks and other structures.

The qualitative indicators of the voltage of power supply consumers, according to standards [1,2], should meet one of the most important requirements, which is the fact that the rated voltage capability should be (+-)10%. Above this range, voltage magnitude may cause malfunctions of power supply consumers, inadmissible overvoltage, and, in some cases, a fire outbreak [3,4].

Voltage surges beyond voltage capability in household power supply networks are not unique. In apartment outlets a higher than the rated voltage of 220 V may occur. The causes of high voltage may vary largely, while the most dangerous are the faults occurring in the zero transmission lines of cables running from the substation both inside the substation and in the entrance control cabinet. It has to be mentioned that apartments still lack protective devices to prevent overvoltage violations beyond permissible threshold to secure voltage stability.

The objective of this study is to scrutinize the regularities of power distribution and voltage magnitude changes caused by faults in zero transmission lines in the power supply networks of large apartment houses, office blocks, offices and other structures.

II. POWER SUPPLY SCHEME OUTLINE

Substations provide large apartment houses with power

supply from 3-phase 380 V power distribution units through zero phase dead grounding. This means that from the control cabinets placed at building entrances, 3-phase and zero phase transmission lines reach all the floors of an apartment house.

In substations the secondary reel of power transformers (PT) have star-shaped junctions. The neutral point of their junction, called zero, is connected to the grounding system of the substation.

The voltage between any phase and zero transmission lines is 220V. Regardless of the number of apartments supplied by the phases and how many household appliances are used at the given moment, the power of the current in the apartment outlets will be the same.

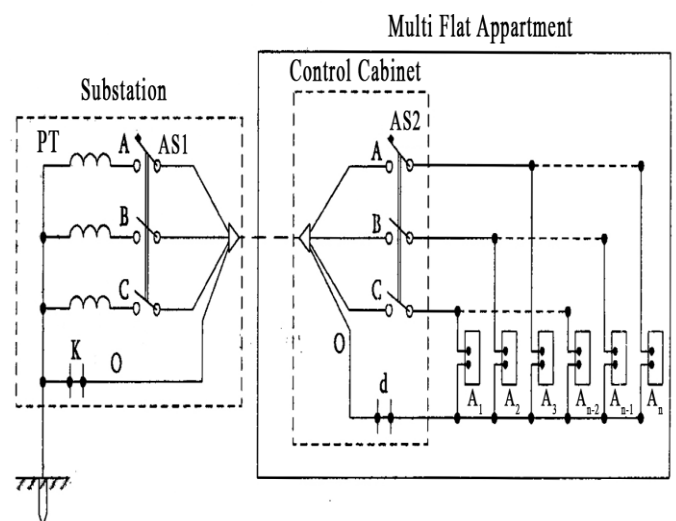

Figure 1 Substation - the power supply scheme of large apartment houses

In case faults occur in zero transmission lines (as a result of weak switches, oxidation, inflammation, poor electrical mounting) in the substation switchboards (point k) or building entrance control cabinets (point d), the power supply pattern in apartments changes totally. Let us consider this change according to picture 1.

From substation the current through four transmission line cables reaches the entrance control cabinet by the automated switch (AS1).

In the control cabinet the main automated protective switch (AS2) (picture 1), automated switches for each apartment, and meters are mounted (picture 2 a). In the control cabinet the zero transmission line is connected to the terminal blocks and is transmitted from there to the meters, from which two transmission lines (zero and phase) go to the corresponding apartments (A1, A2...An). 3-phase voltage is distributed to the apartments so that phases A, B, and C are loaded equally.

D. A. Simonyan, IIAP NAS RA, Yerevan, Armenia
A. A. Gasparyan, A. A. Gasparyan, NPUA, Yerevan, Armenia

III. THEORETICAL OUTLINE

Let us assume that we have an ordinary situation at the power supply network, apartments are supplied by 220V power of voltage. Let us study apartments A1 and A2, whose power supply consuming capacities are known for the given time - P_{A1}, P_{A2} . At the same time it should be mentioned that apartment A 1 receives power supply from phase C, while apartment A2 receives power supply from phase B (pictures 1 and 2).

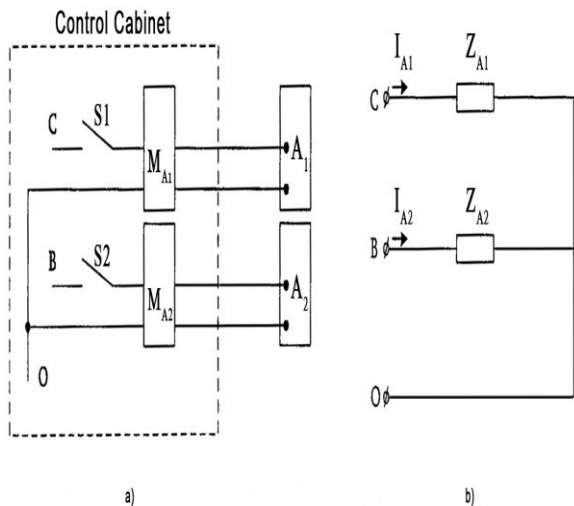

Figure 2 – Supply circuit from the control cabinet to the A1 and A2 apartments. a – Apartment supply circuit, b – apartment supply converted circuit.

Figure 2a illustrates the electric scheme of power supply of apartments 1 and 2 from the control cabinet. Apartment automated switches (S1, S2,...Sn) and power supply meters ($M_{A1}, M_{A2} \dots M_{An}$).

Figure 2 illustrates the replacement electric scheme of apartments A1 and A2.

Now the consumer currents according to phases must be defined. It is calculated by Ohm’s law, having the phase voltage and consumer capacity [5,6].

Accepting that consumers have only active strength for apartments 1 and 2 we come up with the following:

$$I_{A1} = \frac{P_{A1}}{220} \text{ A}; \quad I_{A2} = \frac{P_{A2}}{220} \text{ A} \quad (1)$$

In fact, there are multiple power supply consumers in each apartment. In terms of household appliances, we can state that in each apartment consumers are joint in a parallel mode. Defining the total strengths of the apartments as Z1 and Z2 accordingly, and based on equation (1) we come up with the following equation:

$$Z_{A1} = \frac{U}{I_{A1}} = \frac{220^2}{P_{A1}} \text{ Ohm}; \quad Z_{A2} = \frac{220^2}{P_{A2}} \text{ Ohm} \quad (2)$$

Now let us assume that there has been a fault in the zero transmission line in the control cabinet or substation (point k at the substation and point d in the control cabinet). In this case the power supply consumers at apartments A1 and A2 will be joint consecutively and supplied from linear voltage of 380V of phases B-C. The electric scheme of apartment supply replacement (picture 2b) will look as in picture 3:

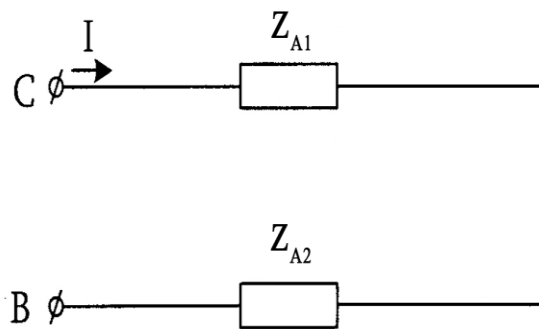

Figure 3. A1 and A2 power supply converted circuit, when zero transmission line faults occur.

The total resistance of the circuit (picture 3) will be as follows:

$$Z = Z_{A1} + Z_{A2} \text{ Ohm.} \quad (3)$$

Proceeding from equation (2) we derive:

$$Z = 220^2 * \frac{P_{A1} + P_{A2}}{P_{A1} * P_{A2}}, \text{ Ohm.} \quad (4)$$

The current which flows by the subsequently joint resistances will be as follows:

$$I = \frac{380}{Z} = \frac{380}{220^2} * \frac{P_{A1} * P_{A2}}{P_{A1} + P_{A2}} \text{ A} \quad (5)$$

The voltage magnitude in apartment A1 will be the following:

$$U_{A1} = I * Z_{A1} = 380 * \frac{P_{A2}}{P_{A1} + P_{A2}} \text{ V} \quad (6)$$

The voltage magnitude in apartment A2 will be the following:

$$U_{A2} = I * Z_{A2} = 380 * \frac{P_{A1}}{P_{A1} + P_{A2}} \text{ V} \quad (7)$$

If the correlation of the voltages distributed between apartments A1 and A2 is defined as K, from equations (6) and (7) we will come to the next equation:

$$K = \frac{U_{A1}}{U_{A2}} = \frac{P_{A2}}{P_{A1}} \quad (8)$$

Besides, we know that $U_{A1} + U_{A2} = 380 \text{ V}$ and $U_{A1} = K * U_{A2}$, we obtain the following:

$$U_{A1} = 380 * \frac{K}{K + 1} \text{ V} \quad (9)$$

$$U_{A2} = 380 * \frac{1}{K + 1} \text{ V} \quad (10)$$

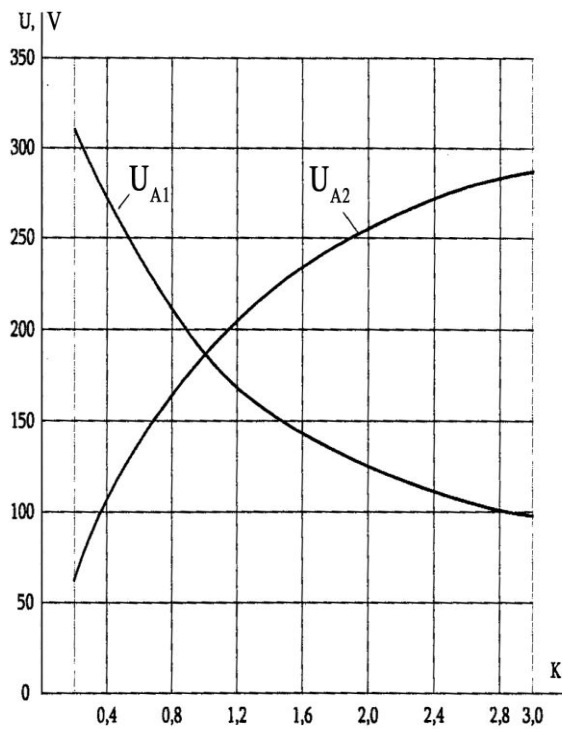

Figure 4 Resulting from a zero transmission line fault, apartment A1 and A2 voltage magnitude dependence on the correlation of the power consumed by them.

Defining K 's values as $(0,2...3,0)$, proceeding from equations (9) and (10), we can calculate the distributed voltage magnitudes in apartments A1 and A2 subsequent upon the zero transmission line fault.

In picture 4, $U_{A1} = f(K)$ and $U_{A2} = f(K)$ characteristics are demonstrated.

As we can see from the characteristics we have come up with, subsequent upon zero transmission line faults the voltage in apartment A1 can change from 63,3 V up to 285,3V, in apartment A2 the change can be from 316,6 V to 95V, when K changes from 0,2 to 3,0.

Thus, as a result of zero transmission line faults, depending on the power consumption of the household appliances at the given moment, apartments can be under inadmissible magnitude of high voltage, which can cause a number of emergency situations, such as inflammation, fire, and huge economic losses.

IV. CONCLUSION

1. In the power supply system zero transmission line faults can cause inadmissible power supply surge in large apartment houses.
2. Big voltage changes beyond voltage capability depend on the workload of different phases at the moment when zero transmission line faults occur.
3. By the derived equations, in case of different capacities of power supply consumers, corresponding voltage magnitudes can be calculated.
4. In case of zero transmission line faults, according to the derived equations and the outline and proceeding from the powers of the supplied consumers, voltage magnitudes on the latter can be

defined without difficulty.

5. Research has shown that corresponding protective devices – special automatic circuit breakers – should be used to avoid voltage magnitude surge beyond voltage capability.

REFERENCES

- [1] ГОСТ 13109-97 "Норма качества электрической энергии в системах электроснабжения общего назначения". М.- 1997.- 37с.
- [2] ГОСТ 771-77 "Допустимое отклонение номинального напряжения электросети: М.- 1977.- 46с.
- [3] Савина Н.В. Качество электроэнергетики: Учебное пособие.- М.- 2014.- 182с.
- [4] Карташев И.И. Качество электроэнергии в системах электроснабжения.- М.- 2000.- 120с.
- [5] Электротехника Борисов Ю.М. и др. Энергоатомиздат, М.- 1985.- 552с.
- [6] Бессонов Л.А. Теоретические основы электротехники.- Высшая школа.- М.- 1967.- 775с.
- [7] Մարտնադիր N2670A. Պաշտպանիչ սարք Ա.Ա. Գասպարյան, Ս.Ք. Բաղդասարյան, Ն.Ա. Գասպարյան.- Գրանցված է 27.08.2012:
- [8] Thai Nguyen & Yuan Liao, "Transmission Line Fault Type Classification Based on Novel Features and Neuro-fuzzy System". Electric Power Components and Systems, Volume 38, 2010 - Issue 6. Pages 695-709
- [9] Yongle Wu, Meijun Qu & Yuanan Liu, "A Generalized Lossy Transmission-Line Model for Tunable Graphene-Based Transmission Lines with Attenuation Phenomenon", Scientific Reports volume 6, Article number: 31760 (2016)
- [10] Sachdev, M. and Aggarwal, R. K. 1998. A technique for estimating transmission line fault locations from digital impedance relay measurements. IEEE Trans. Power Delivery, 3(1) January: pp 121-129
- [11] Liao, Y. 2008. Fault location for single-circuit line based on bus impedance matrix utilizing voltage measurements. IEEE Trans. Power Delivery, 23(2) April: 609-617.
- [12] Siu Ki Lau, "Open-circuit fault detection in distribution overhead power supply network", Journal of International Council on Electrical Engineering, Volume 7, 2017 - Issue 1, 2017. Pages 269-275
- [13] Zhang, N. and Kezunovic, M. 2005. Coordinating fuzzy ART neural networks to improve transmission line fault detection and classification. 2005 IEEE Power Engineering Society General Meeting, 1 June: 734-740. San Francisco, CA
- [14] Silva, K. M., Souza, B. A. and Brito, N. S.D. 2006. Fault detection and classification in transmission lines based on wavelet transform and ANN. IEEE Trans. Power Delivery, 21(4) October: 2058-2063.
- [15] Gracia, J., Mazon, A. J. and Zamora, I. 2005. Best ANN structure for fault location in single and double-circuit transmission lines. IEEE Trans. Power Delivery, 20(4) October: 2389-2395.
- [16] Lin, W. M., Yang, C. D., Lin, J. H. and Tsay, M. T. 2001. A fault classification method by RBF neural network with OLS learning procedure. IEEE Trans. Power Delivery, 16(4) October: 473-477