

Geometrical Calibration System for Rotating Bi-Planar Radiography Instrument

Jae-Seong Han, Sang-Hoon Ji, Sang-Moo Lee, Su-Jeong You*

Abstract—There are many image-guiding systems which provide a surgeon with surgical information including location or orientation of tools and bodies such that they help the surgeon monitor the surgery during the operation. But these image-guiding systems may suffer from imaging distortion due to their mechanical deformations. Therefore, it is needed for the systems to preserve their good localization ability with the calibration process in which the precise radio-projection geometry is determined for X-ray image. But, it is very difficult to reduce deformation error with calibration of the imaging system because of its high complexity of mechanical model. So, in this paper, we suggested a simple calibration method based on a series of laser images, which can be applicable to on-line calibration procedure.

Index Terms—Geometrical calibration, Rotating bi-planar radiography, Intra-operative imaging, On-line calibration

I. INTRODUCTION

In recent times, many companies have proposed several types of image-guiding systems that provide surgical information to help a surgeon monitor the surgery during the operation and decide suitable actions [1][2].

There are two types of image-guiding systems. First, the indirect imaging system calculates the pose of instruments using localizing tool externally attached on the instruments and their geometric model. The indirect imaging system was widely used during the early stages of image-guiding systems because it does not invoke radiation exposure. However, there are limitations in the application to flexible human bodies that cannot be estimated using external instruments. Secondly, there is a system that uses direct radiographic images. Recently, the use of this system has increased because of its good recognition of movement of the organs, bones, and surgical instruments in the body. In particular, a bi-planar radiographic imaging system can always figure out the positions of spectacular points with two X-ray images during the operation.

However, it often happens that the bi-planar imaging system is degraded by its mechanical deformations.

This work was supported by KITECH R&D Program (Project Name: Development of Soft Robotics Technology for Human-Robot Coexistence Care Robots) funded by the Government of Korea.

Jae-Seong Han, University of Science and Technology, Ansan, Republic of Korea, +82-31-8040-6322

Sang-Hoon Ji, Robot R&D Group, Korea Institute of Industrial Technology, Ansan

Sang-Moo Lee, Robot R&D Group, Korea Institute of Industrial Technology, Ansan

***Correspondence. Su-Jeong You**, Robot R&D Group, Korea Institute of Industrial Technology, Ansan

Therefore, it is very important to preserve its good localization ability through the calibration process in which the precise radio-projection geometry is determined for each X-ray image. However, it is very difficult to reduce deformation errors through calibration of the imaging system because of the high complexity of the mechanical model. Furthermore, the method of calibrating the bi-planar imaging system has been seldom researched.

Gorges built a realistic model of an acquisition geometry to assess the physical behavior of a C-Arm [3] and suggested a calibration method, which the acquisition geometry of the C-arm was predicted to have a mean 2D reproduction error of 0.5 mm. However, it takes a long time to apply the methodology for the calibration because the method was designed based on the use of multi-image calibration.

Several methods using X-ray calibration phantoms have been proposed for the geometric calibration of C-arms [4]–[8]. The phantoms consist of X-ray opaque markers that can be detected in the radiographic images. From a set of detected markers and their corresponding model points, the projection geometry can be recovered for each single image frame. The image-based calibration methods have a drawback of resolution, because their resolution errors are approximately 1 mm, which are not suitable for precise surgery.

Thus, in this paper, we suggest an effective and fast calibration method for obtaining a series of radiographs, which can be extended to be used as an online calibration procedure. To achieve this purpose, we invented a calibration sensor module in order to calibrate the mechanical deformation of a rotating X-ray imaging system, such as the geometrical transformation of X-ray tubes and the detectors on the gantry of the platform. The resolution of this sensor is significantly higher than the radiation image-based method.

In this paper, we describe our calibration sensor modules as follows: 1) kinematics and transformation model of our bi-planar imaging platform, 2) major parameters of the model distortion, 3) the calibration sensor module for estimation of the major parameters, 4) implementation. And we verify the effectiveness of our sensor system through simulation results and real radiographic images.

II. ROTATING BI-PLANAR RADIOGRAPHY PLATFORM

Our rotating bi-planar radiography platform consists of an O-shaped gantry, a stator, and two imaging systems as shown in Fig. 1. There are several movements in the imaging system. The gantry goes around axis z (Rotation) and axis x (Tilt). Moreover, the distance along the central ray is adjustable by a motorized linear stage installed behind the detector.

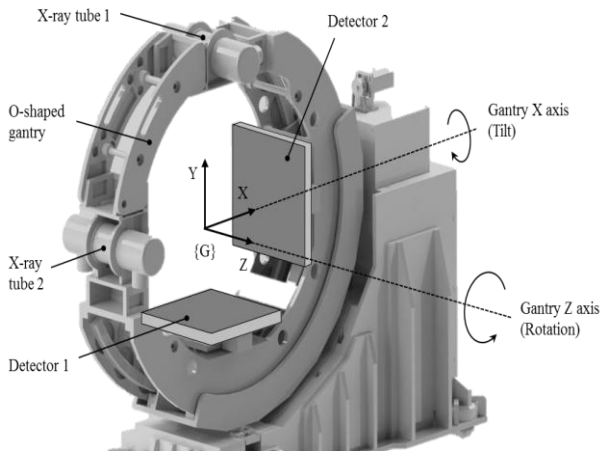

Fig 1. Simplified 3D model of the bi-planar radiography platform

Each X-ray beam of the imaging systems is projected on the corresponding detector and their projections are orthogonal to each other. Radiographic views $\{I_1, I_2\}$ of the object $\{O\}$ are produced as shown in Fig. 2.

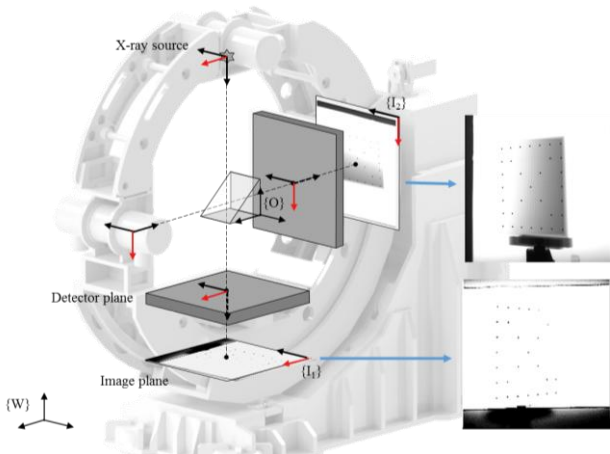

Fig 2. An X-ray object is placed in the center of the gantry

Even though the O-shaped gantry is designed to be rigid, the system undergoes slight mechanical bending due to the weight of the X-ray tubes and the gantry during tilts and rotations. As a result, relative positions of the X-ray sources and detectors vary during the rotation motions. The mechanical transformation of the gantry invokes the image distortions of the radiography (I_1, I_2) and impairs the localization ability of the system.

To resolve this issue, we focused on a geometric model of the rotating bi-planar imaging system and measurement of the deformation, along with presenting a measuring technique of major calibration parameters. In the rest of this chapter, the analysis of our imaging system is presented, which is constructed to design and implement a novel motion tracking system

A. Geometry of a pair of the X-ray Equipment

The geometric relationship between an X-ray source and a detector can be modeled as the image projection model of pinhole camera as shown in Fig. 3. The pixel location where the central ray intersects the detector plane is called as the principal point p_p .

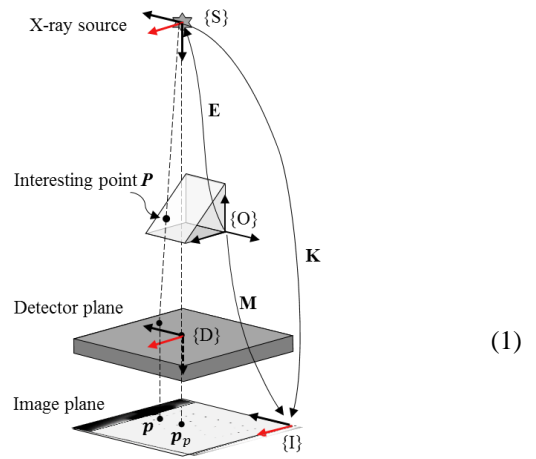

Fig 3. Geometry model of a pair of the imaging devices

The image projection is described with projection matrix M :

$$p = MP$$

$$M = KE = \begin{bmatrix} f & 0 & u_p & 0 \\ 0 & f & v_p & 0 \\ 0 & 0 & 1 & 0 \end{bmatrix} \begin{bmatrix} R & t \\ 0^T & 1 \end{bmatrix} \quad (2)$$

where P is the relative position of the interesting point in the cartesian X-ray Source $\{S\}$ and p is the point where P is projected to the X-ray image plane. K is a 3×4 matrix containing intrinsic parameters of focal length f , principle point $p_p = (u_p, v_p)$, and extrinsic parameter E defining the orientation R and position t of the imaging system in a coordinate system.

The intrinsic parameters describe the projection parameters from the X-ray source to the flat panel detector and f is the focal length in pixels; $\alpha, \beta,$ and γ are the detector rotation angles around each of the $x, y,$ and z axis, respectively.

The point of interest of the object can be localized from the projection with the calibration parameters. The source image distance (SID), from an X-ray tube to a corresponding X-ray image, is defined as the product of the focal length and pixel size of the detector.

B. Geometry of the Bi-planar X-ray imaging system and its simplified distortion model

For the geometric model of the bi-planar X-ray imaging system, it is required to determine position and orientation of the X-ray source and the flat detector, which are obtained by the following procedure. First, four corner points of the X-ray tube mounting are localized. The centroid of the corners is then calculated and the initial value of the offset from the X-ray source is determined by referencing the blueprint of the imaging system. Finally, the centroid position of X-ray detector can be calculated as shown in Fig. 4.

To obtain a simplified model of the distortion of the gantry, the selection of proper measurement points is required along with a record of a series of location of the points during the gantry rotation.

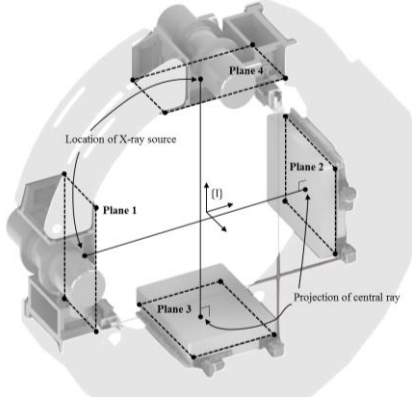

Fig 4. Illustration of planes.

The measuring method is based on the kinematics model of the gantry. We used a simulation method based on the CAD software, and each measuring point is recorded with the gantry orientation. The principle point and SID are then estimated from the data.

It is possible to estimate some variations in the calibration parameters through an observation of the distortion patterns of the source-detector during the rotation motion. From this information, it is possible to select major parameters to be considered for the calibration. Consequently, we need a small set of measurements to calibrate and design the calibration sensor modules such that they are simpler than high-dimensional measuring devices such as an optical tracking system.

The simplified model with major calibration parameters represents the geometrical relations of the source-detector and are independent of the gantry orientation. According to the simulation result, the principle point moves only along the plane of the detector. Because the effect of the out-of-plane rotation is minor on the system calibration and in-plane rotation can be assumed to zero, the rotation has insignificant impact on the calibration result. Additionally, the SID of the system, i.e., the translation along a line orthogonal to the detector plane, is observed to be small, which could be neglected. As a result, the calibration parameters can be narrowed down to two variables, t_x and t_y , which need to be measured with the calibration sensor system. These major parameters obtained by the experiment are presented in

$$\zeta = (u_p, v_p) \quad (3)$$

where u_p and v_p are the principal points, which are determined by the pixel pitch of the detector and the position of the X-ray source. Because the pixel pitch is unique, the principal point is influenced by the position of the X-ray source, which is limited to one plane parallel to the detector. When the nominal position of the X-ray source is represented in the detector coordinate system, the positional change is represented as a two-dimensional vector $t' = (x, y)$. Thus, the position changes of the X-ray sources in the bi-directional imaging system can be defined by Eq. (4), and are applied to the image calibration as shown in Fig. 5.

$$t'_1 = (x_1, y_1), t'_2 = (x_2, y_2) \quad (4)$$

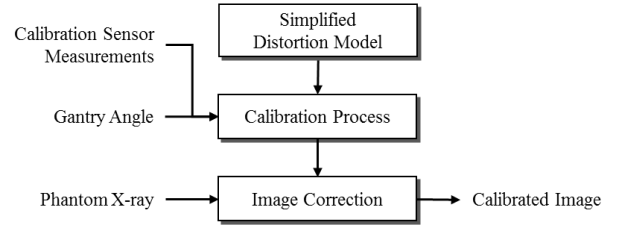

Fig 5. Gantry calibration process diagram.

III. CALIBRATION SENSOR SYSTEM

The calibration sensor system is an external sensor system for geometrical calibration of the X-ray imaging system. This sensor system enables online calibration of the X-ray system, rather than using a method that projects an expensive calibration phantom onto the X-ray system. When compared to a 3-D optical tracking system, our sensor system requires a smaller space to measure the deformation of the position of the X-ray tube and detector.

A. Design of sensor system and laser image processing algorithm

The goal of the sensor system is estimating major parameters of an X-ray acquisition geometry in a normal and transformed state of the gantry, which are computed using measurements of the relative position between an X-ray tube and corresponding detector. To measure the displacement, a concept of laser tracking system is used.

As illustrated in Fig. 6, a laser beam module is rigidly attached to the X-ray tube housing and a laser head is pointed towards a paper target mounted at the side of a detector. A camera is also placed beside the detector to observe the target and localize laser spots on the target. The proposed sensor system measures 2 DoF (Degree of Freedom) relative transitions between the two modules, the laser module, and camera module.

The laser beam makes a red spot on the target. The laser spot image is also visible on the other side of the target, and the mirror prism reflects the image to the camera. It is assumed obstruction of the laser will not occur. This method not only provide more contrast between the laser and the target but also protects the camera sensor because of a decreased intensity of the laser. The laser position on the camera is determined by finding the beam's centroid. The 2-D position data of the laser is used in a calibration algorithm, which is explained in the next subsection.

The tracker module, consisting of a camera and a mirror prism, is fixed on an aluminum mount, and it is assumed that the distortion of the mount will not occur. The target paper is attached to the mirror prism module aligned to the camera module. This tracker module is rigidly mounted on a micro-positioning stage having 2 DoF linear motions parallel to the table as shown in Fig. 6. The 1 DoF of the stage is directed to the laser module and the direction of the other 1 DoF is orthogonal to the laser module. By adjusting the dials on the micro-stage, the tracker module translates to desired position along an axis orthogonal to the direction of the laser.

More specifically, the calibration system utilizes a lens

correction circular laser module (5 mW, approximately 650 nm), a paper target (80 g/m², white), a 50-50 mirror prism, and a CMOS camera. Diameter of the laser beam is approximately 1 mm, and the paper target is placed in front of the mirror prism. The mirror prism reflects 50% of incident light through 90°. The laser beam passes through a 2:1 telescope before reaching the camera. The CMOS camera captures the laser images in 10 frame-per-second and has a pixel size of 3.75 μm × 3.75 μm. Additionally, a fixed focus lens is used.

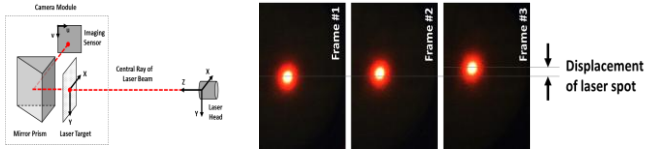

Fig. 6. (a) Scheme of calibration sensor system. Laser beam is projected on a laser target and laser intensity is reduced towards camera sensor through mirror prism; (b) Laser images acquired from the camera with translations of laser head. Displacement of laser centroid between frames is observable.

To compute position and size of the laser image, the multivariate Gaussian distribution fitting method is used on the image frames acquired from the camera module. The fitting method calculates the Gaussian distribution of the pixels of the laser image according to each axis of the image plane. The mean and standard deviation of the distribution represent the beam centroid and diameter, respectively, in the pixel coordinate system. By selecting a specific deviation as the threshold, it is possible to extract the laser image from the background.

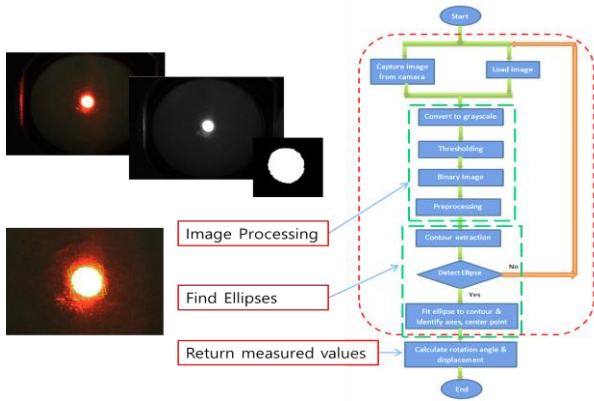

Fig. 7. Algorithm for calculating the centroid of the laser image

B. Geometrical Relationship with Bi-Planar Platform

To measure the displacement of the X-ray frame in a direction parallel to the detector plane, the laser module is attached firmly to the X-ray fixing frame, and the camera module is fixed to the side of the detector frame (see Fig. 8(a)); furthermore, the direction of the laser beam is aligned with the X-ray projection direction. The geometric relationship between the diagram of the single compensation sensor and the imaging device is shown in Fig. 8(b).

In Fig. 8(b), the plane shift from X-ray source frame S to S' corresponds to $t' = (x, y)$ and τ_1 in Eq. (4). The displacement of the X-ray frame is equal to the displacement of the laser module and can be confirmed by the displacement of the center of the laser projected on the target plane of the

correction sensor, as revealed by the geometric relationship in the figure. As a result, the geometric correction can be performed using comparing the center of the laser when the gantry is in a steady state (rotation angle: 0) and the center of the laser at the specific rotation angle.

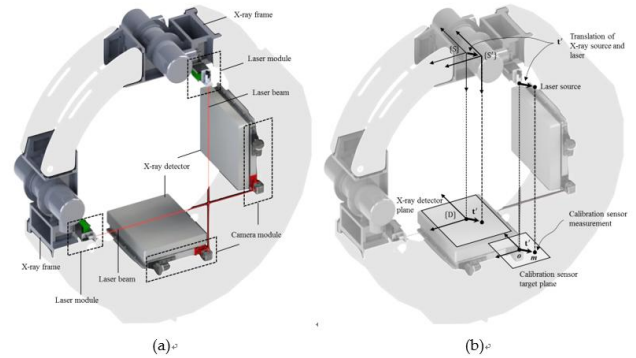

Fig. 8. Calibration sensor system with an X-ray imaging system (a). Brief illustration of the geometrical relationship between the sensor system and the X-ray (b). Coordinate frames of X-ray source and detector plane are denoted by {S} and {D}. The dotted lines represent laser beam and central ray of the X-ray. Laser beam is parallel to the central ray.

IV. IMPLEMENTATIONS

A. A Calibration Sensor System

To make a measurement model of the proposed calibration sensor system, a single sensor system was settled down on vibration-free table and a set of sensor data was collected as shown in Fig 6. The sensor data consists of laser image and corresponding relative translation between the camera and the laser module. Displacement of laser is measured by using two images, first image is captured at initial position of the camera module and second one is captured at desired position. Laser centroid of each image is calculated using laser image detection algorithm and is represented as image coordinates in pixels. In this experiment, the relative displacement of the laser module is from 0 μm to 600 μm and minimum step is 20 μm. Desired displacements of the laser are 31 and sensor data is collected at each position. Finally, a linear regression was performed on the measurements. The linear regression slope and R-square were determined to be -15 pixels/μm and 0.9967, respectively.

Experimental evaluation of a single calibration sensor system is performed on our bi-planar radiography platform. Setup for this experiment was equal to the configuration as shown in Fig 9

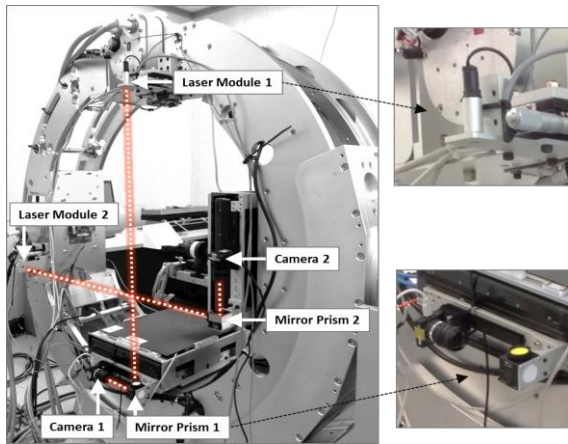

Fig 9. Calibration sensor system on the radiography platform

In Fig. 9, Camera 1 and mirror prism 1 are aligned with the laser pointer at the X-ray tube. Sensor module 2 and laser module 2 are aligned horizontal direction at the initial position of the gantry. Dotted lines represent laser beam

The laser module could move precisely because of micro stage holding the module. During the camera captures laser image, the laser module displaced $600 \mu\text{m}$ from initial position. Displacement of the laser module is measured by using two sets of images, first set is an image captured at initial position and second set has 16 images captured after the displacement. This measuring process was repeated 5 times, and the results are presented in Table I.

Performance of the calibration sensor system was expected as having accuracy of $100 \mu\text{m}$, and the system was designed to meet the performance. As revealed in this experiment, accuracy of the sensor system meets the requirement of calibrating bi-planar radiography platform.

Table 1. Measurement of laser module displacement

Number	Mean	Standard deviation	Error
1	611.8 μm	2.5 μm	11.8 μm
2	605.9 μm	0.9 μm	5.9 μm
3	606.5 μm	9.6 μm	6.5 μm
4	606.8 μm	8.4 μm	6.8 μm
5	608.3 μm	6.5 μm	8.3 μm

B. Distortion Measurement of Bi-planar X-ray Platform

Major parameters (t_x, t_y) of geometric calibration have been derived for decreasing the number of measurements while maintaining calibration accuracy. To measure the parameters of our bi-planar radiography platform, proposed calibration sensor systems have been implemented to the platform. Also, the major parameters are measured by using a commercially available 3-D motion tracking system. These experimental setups and processes are described in this section.

Implementation of two calibration sensor systems is shown in Fig 10. Tracker part of the sensor system, each camera with mirror-prism module, was attached on side of X-ray detector where the sensor system does not obstruct an X-ray object while acquiring the radiographs. Another part, laser module

with 2-axis micro stage, was installed on the side of X-ray housing. To align the laser and the tracker module, the stage of the laser module was adjusted, thus centered laser images are gathered with the camera.

Measurements of distortion of X-ray imaging system are obtained for different orientation of gantry namely for $\theta \in [-45, 30]$. The measurement from the calibration sensor system and corresponding orientation of the gantry consist a dataset, which is an input of calibration process.

To collect the datasets, the calibration sensor system was initialized and began measuring the distortion continuously. While the sensor system running, the gantry rotates approximately 5 degrees and holds 5 seconds to stabilize then the gantry angle was recorded manually. Controlling the gantry and monitoring the angle are available by using a control panel of the platform. By repeating the data collection procedure, each data can be under exactly the same condition and is mapped to a specific gantry angle. The measurement step is performed 5 times in the range of the gantry angle.

Distortion measurement step was also performed with an optical tracking system(OTS), which is for comparison with proposed calibration sensor system. The OTS is well-known 3D measurement system in this field. The tracking system consists of a positioning sensor, a host computer, and optical trackers, and these components are communicates by wire. Optical trackers are attached on the side of each X-ray tubes and detectors as presented in the Fig 11. These trackers are activated by the OTS and emits infrared light. Then the OTS identifies each tracker and calculates position and orientation at frequency of 100Hz. Same as previous measurements, the case of using the calibration sensor system, the gantry rotates ~ 5 degrees and holds 5 seconds, which is repeated range of $[-45, 30]$ degrees.

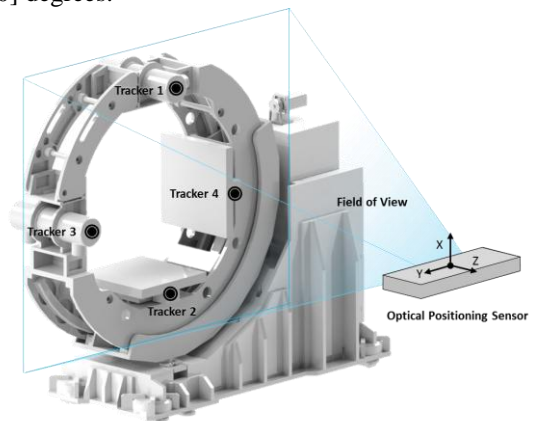

Fig 10. Locations of the trackers and configuration of the positioning sensor {NOTE- mdpi: A caption on a single line should be centered.}

From the measurement data of distortion of bi-planar radiography platform, geometric calibration was performed and evaluation on the propose calibration sensor system has been made. The results are presented in following subsection.

Proposed calibration sensor system is evaluated in quantitatively and qualitatively. Since resolution of the OTS is enough to evaluate the performance of the proposed sensor system, measurement from the OTS is used as a ground truth. Raw datasets of the OTS are 6-D vectors representing position and orientation of each X-ray tubes and detectors,

thus those are converted to 2-D vectors describing position of X-ray tubes relative to corresponding detectors. ...

Compared to the optical motion tracker, proposed calibration sensor system performed with plausible accuracy. In terms of line-of-sight limitation, our sensor system requires less volume to be cleared for satisfying the line-of-sight requirements than common OTSs.

V. CONCLUSIONS

We proposed the calibration sensor system for an orthogonally arranged bi-planar X-ray imaging system. The quantitative and qualitative results of our studies shows that the sensor system has considerable advantages on resolution of calibration parameters of the X-ray imaging devices in that its accuracy was about 0.1mm in determining the translations of the X-ray sources

REFERENCES

- [1] Grimson E., Lorigo L., Kapur T., Kikinis R., "Image Guided Surgery", *Sci. Am.* pp.54–61, 1999.
- [2] Craven M. P., Pecchia L., Martin J. L., "User requirements for image-guided navigation in spinal surgery", *IFMBE Proc.* 2013 pp.2115–2118, 2013.
- [3] Gorges S., Kerrien E., Berger M. O., Troussset Y., Pescatore J., Anxionnat R., Picard L., "Model of a vascular C-arm for 3D augmented fluoroscopy in interventional radiology", *Med. Image Comput. Comput. Interv.* pp.214–222, 2005.
- [4] Cheryauka A., Brehm S., Christensen W., "Sequential Intrinsic and Extrinsic Geometry Calibration in Fluoro CT Imaging with a Mobile C-arm", In *SPIE Medical Imaging*, Vol. 6141, p. 61412H–61412H–8, 2006.
- [5] Johnston S. M., Johnson G. A., Badea C. T., "Geometric calibration for a dual tube/detector micro-CT system", *Med. Phys.* pp.1820–1829, 2008.
- [6] Selby B. P., Sakas G., Walter S., Stilla U., "Geometry calibration for X-ray equipment in radiation treatment devices and estimation of remaining patient alignment errors", In *Proc. SPIE 6913, Medical Imaging 2008*, Vol. 6913, 2008.
- [7] Kim Y., Kim W., Park S., Kim J.-H., "Calibration method for microscale stereo X-ray imaging system", *Int. J. Precis. Eng. Manuf.* pp.877–882, 2012.
- [8] Seo C.-W., Cha B. K., Kim R. K., Kim C.-R., Yang K., Huh Y., Jeon S., Park J. C., Song B., Song W. Y., "Development and operation of a prototype cone-beam computed tomography system for X-ray medical imaging", *J. Korean Phys. Soc.*, pp.129–134, 2014.
- [9] Moura D. C., Barbosa J. G., Reis A. M., Tavares J. M. R. S., "A Flexible Approach for the Calibration of Biplanar Radiography of the Spine on Conventional Radiological Systems", *Comput. Model. Eng. Sci.*, pp.115–137, 2010.
- [10] Orth R. C., Wallace M. J., Kuo M. D., "C-arm cone-beam CT: general principles and technical considerations for use in interventional radiology", *J. Vasc. Interv. Radiol.* pp.814–820, 2008.
- [11] Siewerdsen J. H., Moseley D. J., Burch S., Bisland S. K., Bogaards A., Wilson B. C., Jaffray D. A., "Volume CT with a flat-panel detector on a mobile, isocentric C-arm: pre-clinical investigation in guidance of minimally invasive surgery", *Med. Phys.*, pp.241–254, 2005.
- [12] Gorges S., Kerrien E., Berger M.-O., Troussset Y., Pescatore J., Anxionnat R., Picard L.; Buc F., "An effective technique for calibrating the intrinsic parameters of a vascular C-arm from a planar target", In *Proc. SPIE 6141*, pp. 1–10.
- [13] Ryu S., "Development of Cost-effective Deformation Sensor System for High Precision Medical Radiation Imaging", 2013.
- [14] Amiri S., Wilson D. R., Masri B. A., Anglin C., "A low-cost tracked C-arm (TC-arm) upgrade system for versatile quantitative intraoperative imaging", *Int. J. Comput. Assist. Radiol. Surg.*, pp.695–711.
- [15] Moura D. C., Barbosa J. G., Tavares J. M. R. S., Reis A. M., Tavares M. R. S., Reis M., "Calibration of Bi-planar Radiography with a Rangefinder and a Small Calibration Object", In *Lecture Notes in Computer Science*; Springer, 2008, Vol. 5358, pp.572–581.
- [16] Mitschk M. M., Navab N., Schütza O., "Online geometrical calibration of a mobile C-arm using external sensors", In *SPIE Proceedings*, Vol. 3976, pp.580–587, 2000.

- [17] Hu Z., Gui J., Zou J, Rong J., Zhang Q., Zheng H., Xia D., "Geometric calibration of a micro-CT system and performance for insect imaging", *IEEE Trans. Inf. Technol. Biomed.*, pp.655–660, 2011.
- [18] Icord C., Rizo P., Sire P., "Vision" Approach of Calibration Methods for Radiographic Systems", 1993.
- [19] Yang K., Kwan A. L. C.; Miller D. F., Boone J. M., "A geometric calibration method for cone beam CT systems", *Med. Phys.*, pp.1695–1706, 2006.
- [20] Mery D., "Computer Vision for X-Ray Testing", Springer, 2015.
- [21] Rougée A., Picard C., Ponchut C., Troussset Y., "Geometrical calibration of x-ray imaging chains for three-dimensional reconstruction", *Comput. Med. Imaging Graph*, pp.295–300, 1993.

Jae-Seong Han He received the B.S degree in Electronic Engineering and Computer Engineering, Chonbuk National University, in 2008. He is currently undertaking Doctor of Robotics and Virtual Engineering, at University of Science and Technology, Korea. From 2008 to 2016, he was Student researcher at the Korea Institute of Industrial Technology, Korea. Since 2017 he is currently Manager at CEMWARE,Inc. His research interests include robot system, computer vision and software engineering.

Sang-Hoon Ji He is a Principal Researcher in Robot R&D Group at Korea Institute of Industrial Technology. He received his BS and MS in Control and Instrumentation Engineering and his PhD in Electrical Engineering and Computer Sciences from Seoul National University, Seoul, Korea in 1995, 1997 and 2007, respectively. From 1997 to 2002, he was a Research Engineer at IAE, Yongin, Korea and from August 2007 to September 2008 he worked as a Deputy General Manager at Doosan Infracore Ltd., Yongin, Korea. His research interests include multi-agent robot systems, robot S/W platform and medical robot.

Sang-Moo Lee He is a Principal Researcher in Robot R&D Group at Korea Institute of Industrial Technology. He received his BS, MS, and Ph.D in Control and Instrumentation Engineering from Seoul National University, Seoul, Korea in 1987, 1989 and 1999, respectively. From 1989 to 1994, he was a Senior Engineer at Daewoo Heavy Industry, Incheon, Korea and from 1999 to 2004 he worked as a Principal Researcher at IAE, Yongin, Korea. His research interests include industrial robot and nonlinear control theory.

Su-Jeong You She is a Research Associate in Robot R&D Group at Korea Institute of Industrial Technology. She received her BS and MS in Control and Instrumentation Engineering and her PhD in Electrical Engineering and Computer Sciences from Seoul National University, Seoul, Korea in 1993, 1995 and 2013, respectively. She worked for four years at LG as a Research Engineer in projects with machine learning and artificial neural network. Her research interests include computer vision, machine learning and human-computer interaction.