

# Study of Future Wireless Technology: Li-Fi

Priyanka Gupta, Pralabh Gupta, Chirag Garg

**Abstract**— Since the day earth exists, human is going develop day by day. New technologies are generated as human beings are developing. Now, internet is a compulsory part of our life. We are using Wi-Fi for internet access. But it has some limitations, so there is a new wireless technology i.e. Li-Fi (Light Fidelity), which overcomes some of the shortcomings of Wi-Fi. This paper consists a study of Li-Fi basics like advantages, limitations, applications and future scope.

**Index Terms**— Li-Fi, Light Fidelity, Wireless technology.

## I. INTRODUCTION

As on date internet is necessity of everyone's life in the world. We are using internet widely at all places like hotels, universities, schools, hospitals etc. using Wi-Fi networks. Wi-Fi uses radio frequencies to deliver wireless internet access and it contains limited bandwidth. Everyone wants right information at right place at certain time. But sometimes it creates frustration when slow speed of internet delays the work and ruined the performance due to sharing of limited bandwidth by substantial number of devices at a time. Thus, there is a need of new wireless technology for data sharing and communication which can overcome the limitations of Wi-Fi. Li-Fi (light fidelity) is a bidirectional high-speed and fully networked wireless communication technology similar to Wi-Fi. Li-Fi is a new wireless technology which can transfer data at a very high speed.

The term Li-Fi was coined by the professor Harald Haas, the chair of mobile communication and teaches at the University of Edinburgh, recognized as the founder of Li-Fi., he discussed the idea of "wireless transfer of data from light" first time at the TED Global conference in Edinburgh on 12 July 2011.

The basic idea of Li-Fi depends upon the variety of intensity of light source i.e. LED (Light Emitting Diode). A light flick due to variation of intensity, when light off it generates code 0 and when light is on it generates code 1. Light flicks so fast that human eye cannot visualize the variation. Thus, code is generated and streamed.

## II. WORKING OF LI-FI

Li-Fi is a Visible Light Communication System. It requires two main components to transmit data from device to another device i.e. first one is a light source and second is device as a receiver (photo sensor). Light source (LED) is at sender's end and photo diode acts as a receiver's element, and convert them in electric current.

Electronics signals are converted into continuous streamed data to be streamed on receiver device.

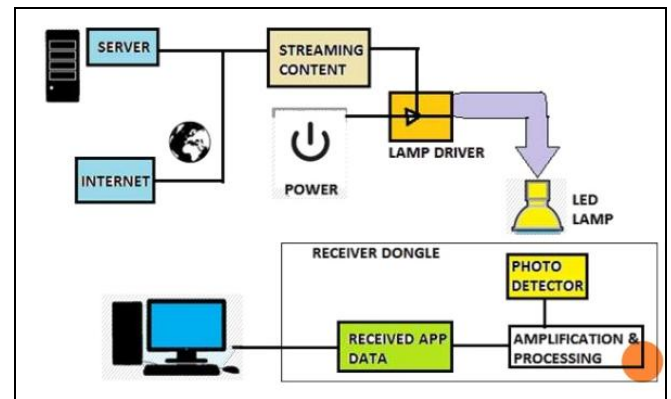

Fig-1: Architecture of Li-Fi

## III. BENEFITS AND ADVANTAGES OF LI-FI OVER WI-FI

- Li-Fi technology provides high speed of data transfer. It can transfer more than 10 Gpbs which is very fast in comparison of other existing technologies like Wi-Fi, Bluetooth, infrared.
- It provides more security of data because light does not pass through walls.
- As Wi-Fi has restricted bandwidth therefore while many users access the internet at a same time at same place its speed goes down. But Li-Fi solves this problem because bandwidth is no issue here.
- Li-Fi can use under water where Wi-Fi doesn't.
- There is no harmful effect on human health of usage of Li-Fi technology because it doesn't use radio frequency.
- Li-Fi can work in air space efficiently where radio frequency can create electromagnetic interference with radio equipment.

## IV. LIMITATIONS OF LI-FI

- The main issue is that light does not pass through objects, if there is any object between sender and receiver then data transmission will stop instantly.
- Interruption in communication may occur due to the interference of lights, sunlight etc. It can make Li-Fi less reliable.

- There should be a direct link between light and receiver otherwise data transfer will not take place.
- It covers small areas for data transfer unlike Wi-Fi.
- We depend on light source for data transmission. If source malfunction then we will lose internet connection.

### V. APPLICATIONS OF LI-FI

- *Under water communication:* Li-Fi can be used for under water communication whereas Wi-Fi does not work properly under water due to the absorption of radio waves in water quickly. Light can easily travel in water that's why data sharing can be easy through the use of underwater vehicle's head and tail lights.
- *In sensitive areas:* Due to concerns over radiations, power plants, nuclear plants are very sensitive areas for using Wi-Fi. Still these places need high speed data sharing. So Li-Fi is a better solution for these types of areas. It uses LEDs for data transfer and it does not emit any electromagnetic interference.
- *Traffic control:* Information can be shared through LED head lights to tail lights of next vehicles that can prevent accidents. Normal traffic lights, street lights can replace with led lights which can co-ordinate with vehicles and this will enhance the management of traffic and safety.
- *In houses:* Now we use Wi-Fi for internet access at homes. Due to the limited bandwidth as we use many devices at a same time internet speed gets slow down. Whereas Li-Fi gives the better solution of this problem, because it does not restricted with bandwidth. In houses television screens, room lights can be used for Li-Fi.
- *In aircrafts:* Wi-Fi is not much suitable for aircrafts, on the other hand Li-Fi can be a better option for internet access in aircrafts. Aircrafts already contain many lights, so there is no need of more wiring and passengers can access higher speed internet form aircraft's light.
- *In hospitals and medical centers:* Due to health concerns Wi-Fi is not allowed in operation theaters in hospitals because it creates electromagnetic interference and can cause the collision of radio signals and medical equipments radiations. Li-Fi does not create any electromagnetic interference because it use LEDs for data transmission and LEDs are already used in rooms, operation theaters for light. Thus, Li-Fi is a better alternative of Wi-Fi.

### VI. FURTHER SCOPE

In future if lights are designed with smaller size LEDs as compared to present sized LEDs, it will flick more times than bigger sized LEDs so will be able to transfer data at faster rate and consume less space. More LEDs can be placed in less space therefore more data can be transferred at high speed at same time period. For more enhancements if both the technologies (Wi-Fi and Li-Fi) used together then it may achieve better results.

### VII. CONCLUSION

We studied about Li-Fi and we got that it eliminates many issues of Wi-Fi still it is not a complete replacement of Wi-Fi, as it has some limitations. This time Li-Fi may not be full replacement of Wi-Fi but there is a need of some approaches and optimizations, efforts it will achieve better results in future.

### REFERENCES:

- [1]Harald Haas, 'Wireless data from every light bulb', TED Global, Edinburgh, July 2011.
- [2]<http://en.wikipedia.org/wiki/Li-Fi>
- [3][seminarprojects.com/s/seminar-report-on-lifi](http://seminarprojects.com/s/seminar-report-on-lifi).
- [4]Richa Kaushal, "Li-Fi- Light Fidelity Technology", IJIR, vol-2, issue-4, 2016.
- [5]Dr.Y.P.Singh, Abhishek Haridas, "Critical Technical Aspect and Extensive Research study of the Light Fidelity", IJIEASR, vol 2, No.9, september 2013.