

Automatic Irrigation System Using Wireless Sensor Networks

Gaurav Soni, Navdeep Singh

Abstract— Wireless sensor networks have become an important tool for modern growers. Sensors provide the ability to monitor conditions from the farm-level down to individual plants. Such sensors include ambient temperature, humidity, soil water content, irrigation pressure, applied water volume, and fertilizer concentration. Commercially-available wireless sensor networks for agriculture have until recently focused on sensor monitoring, but not control. Growers using these systems have a wealth of crop information from sensors, but must implement control decisions using traditional means such as stand-alone irrigation controllers or manual labor. Wireless sensor networks (WSNs) find wide applications in environmental monitoring. MAC protocols play a vital role in controlling the energy consumption in a WSN. It tells the network when and how to access the medium. Time Division Multiple Accesses (TDMAs) are well suited for these real time applications. Because it prevents radio interference, and reduces energy consumptions. In this paper we reviewed the Basic Architecture of Automatic irrigation system using of WSN and some applications of WSN.

Index Terms—Wireless Sensor Network, TDMA, FDMA, MAC.

I. INTRODUCTION

Precision agriculture (PA)[5] refers to a series of practices and tools necessary to correctly evaluate farming needs. The accuracy and effectiveness of PA solutions are highly dependent on accurate and timely analysis of the soil conditions. In this paper, a concept towards an autonomous precision irrigation system is provided through the integration of a center pivot (CP) irrigation system with wireless underground sensor networks (WUSNs). This Wireless Underground Sensor-Aided Center Pivot (WUSA-CP) system will provide autonomous irrigation management capabilities by monitoring the soil conditions in real time using wireless underground sensors. The radio part in a sensor node consumes more energy. So the MAC layer is modified, which controls the radio operations. MAC protocols play a vital role in the energy saving process of a WSN. MAC schemes for sensor networks can be fundamentally categorized into contention-based and scheduling-based schemes. The main advantages of contention based schemes in WSN include; no synchronization requirement, no central scheduler required, more robust to the network dynamics, no clustering necessary, more suitable for event-driven WSNs. However, in terms of energy savings, contention-based schemes are not attractive. Scheduling-based schemes attempt to determine the network connectivity first and design

collision-free links to each node. Links may be assigned as time slots (TDMA), frequency bands (Frequency Division Multiple Access (FDMA)), or spread spectrum codes (Code Division Multiple Access (CDMA)). TDMA schemes [8-9] have a distinct advantage over the other methods in terms of energy conservation [8]. Except for the transmission, receiving and sensing durations, nodes can be put to sleep and highest amount of power savings possible. The main disadvantage of the TDMA scheme is that it requires time synchronization. Commercial standard such as IEEE 802.11 is not suitable for WSNs since the nodes listen at all times and they cannot be used for multi hop purposes.

II. WIRELESS UNDERGROUND SENSOR NETWORKS

A WUSN is mainly formed by underground sensor nodes. However, the network still requires aboveground nodes for additional functionalities such as data retrieval, management, and relaying. Therefore, considering the locations of the sender and the receiver, three different communication links exist in WUSNs, as shown in Fig. 1:

(A) *Underground-to-underground (UG2UG) link*: Both the sender and the receiver are buried underground and communicate through soil [6]. UG2UG links can be employed for multi-hop information delivery.

(B) *Underground-to-aboveground (UG2AG) link*: The sender is buried in the soil profile and the receiver is located above the ground [4]. Monitoring data are transferred to aboveground relays or sinks through these links.

(C) *Aboveground-to-underground (AG2UG) link*: An aboveground sender node sends messages to underground nodes [4]. This link is used for management information delivery to the underground sensors.

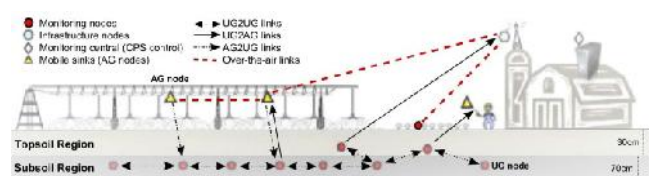

Fig. 1. An example of a precision agriculture cyber-physical system, WUSA-CP, based on Wireless Underground Sensor Networks (WUSNs). A WUSN

can employ three kinds of communication: underground-to-underground (UG2UG), underground-to-aboveground (UG2AG), and Aboveground-to-underground (AG2UG).[4]

Gaurav Soni, Associate Professor, Department of Electronics and Communication Engineering, Amritsar College of Engineering and Technology, Amritsar, India

Navdeep Singh, Assistant Professor, Department of Applied Science, Amritsar College of Engineering and Technology, Amritsar, India

III. WSN ARCHITECTURE FOR AUTOMATIC IRRIGATION SYSTEM[1-7]

The basic scenario consists of a base station/sink and sensor nodes. Each sensor node is equipped with a power amplifier. Thus we could cover up to 1 acre area of the field using this method. Each sensor node will measure the temperature and the moisture level of the soil. For initializing the network, the base station assigned each node with a unique address. Then each node switched to the idle state. In the idle state each node is in receiving mode only. When the base station required collecting the temperature and moisture level of a particular area, it broadcast the address of the sensor node which is deployed over there. All the nodes received this address but only the addressed node responded to this request by sending back the present value of the moisture and the temperature of that region. The other nodes can continue in the idle state. After sending the required data the node goes back to the idle state. This process is repeated for all the nodes. In using direct communication method each sensor node sent its data directly to the base station. If the nodes are far from the base station, each node requires large amount of transmission power. This reduces the system life time. So when the nodes are close to the base station this system is efficient.

A. Sensor node[6]

Each node consists of a moisture sensor and the temperature sensor. Fig. 2 shows the block diagram of sensor node. The node's microcontroller program (programmed in C language) corrected and formatted sensor values and then output the results to the onboard transceiver. The sensing of environment and data transmission occurred whenever it is requested by the base station.

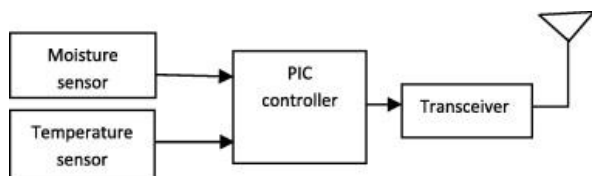

Fig. 2. Sensor node

B. Soil moisture sensor

The Soil Moisture sensor is used as a tool to optimize irrigation and to warn of plant stress at the dry or wet ends of the scale. It is a high performance accurate sensor. Because the probe measures the dielectric constant of the soil using transmission line techniques, it is insensitive to water salinity, and did not corrode over time as does conductivity based probes. The probes are small, rugged, and consumed under a mA of power.

C. Temperature sensor

Thermistors are temperature sensitive resistors. All resistors varied with temperature, but thermistors are constructed of semiconductor material with a resistivity that is especially sensitive to temperature. However, unlike most other resistive devices, the resistance of a thermistor decreased with increasing temperature. That is due to the properties of the semiconductor material that the thermistor is made from.

Resistance drops is a very small value in a range around room temperature. Not only resistance changed in the opposite direction from what we expected, but the magnitude of the percentage of resistance change is substantial.

D. Base station

The base station consists of a transceiver, processor, and LCD display. The basic block diagram is shown in Fig. 3. After getting the value of the moisture level and the temperature, the base station compared this value with the threshold value which is already stored in the database. If the measured value is less than the required value, the controller performs the necessary actions. The same procedure is repeated for all the nodes.

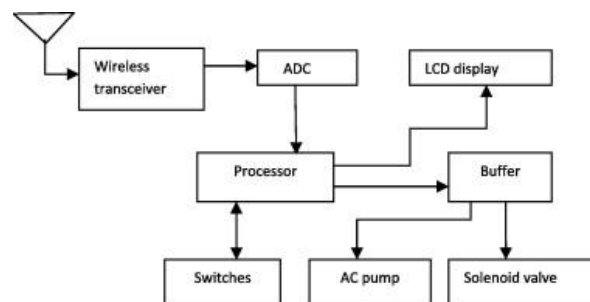

Fig. 3. Base station

E. Solenoid valve

A solenoid valve is an electromechanical valve for use with liquid or gas controlled by running or stopping an electrical current through a solenoid, which is a coil of wire, thus changing the state of the valve. The operation of a solenoid valve is similar to that of a light switch, but typically controls the flow of air or water, whereas a light switch typically controls the flow of electricity. Solenoid valves may have two or more ports: in the case of a two-port valve the flow is switched on or off; in the case of a three-port valve, the outflow is switched between the two outlet ports. Multiple solenoid valves can be placed together on a manifold. Solenoid valves are the most frequently used control elements in fluidics. Their tasks are to shut off, release, dose, distribute or mix fluids. They are found in many application areas. Solenoids offer fast and safe switching, high reliability, long service life, good medium compatibility of the materials used, low control power and compact design. We used these valves to control the flow of fertilizers and water to the mixer. Besides the plunger-type actuator which is used most frequently, pivoted-armature actuators and rocker actuators are also used.

F. Pump

The pump is used for the purpose of pumping water in the storage tank to the field. It works according to the instruction of micro controller. So it could pump the water whenever it is needed.

IV. DATA AGGREGATION METHOD

Data aggregation played a major role in reducing the energy consumption by the sensor nodes and thereby increasing the network life time efficiently. The difference between the data aggregation and data accumulation is that, in data

accumulation the header node collected the data from all the nodes and just bypassed them to the base station without altering the data. But in case of data aggregation the header node collected the data from all the nodes and aggregated them depending on different techniques. The data being sensed by the nodes in the network are transmitted to a base station. In this model base station is fixed and located far from the sensors. Data collected from each node is combined together into a small set of information. Data aggregation is also known as data fusion. Sensor networks contain too much data for an end-user to process. Therefore, automated methods of combining or aggregating the data into a small set of meaningful information are required.

For data aggregation nodes are designed in such a way that if the transmitting node failed, it would not affect the network performance and also due to the presence of error bound the header transmitted the data only if the aggregated data is beyond the limit. Nodes organized themselves into clusters with one node acting as the cluster head. In this case, a sink/base station acted as the super cluster head. All the sensor nodes are grouped into three clusters; each contained six nodes and a cluster head. The communication between sink and cluster heads is based on the TDMA. The communication within each cluster is also based on TDMA method. The basic operation is same as the single – hop method. But here we had two stages of communication.

- (1) Communication between base station and cluster heads.
- (2) Communication between cluster heads and the cluster members.

All the nodes in the network are assigned with a unique address and it is known to the base station. Each node acted as the cluster head based on a TDMA schedule. This schedule is broadcasted to the nodes in the clusters. Whenever the cluster is formed, based on the schedule all the nodes transmitted their energy information to the base station. The node which had the highest energy among all the nodes in a cluster is assigned as the cluster head of that cluster by the base station. Initially all the nodes including the cluster heads are in the idle state. Whenever the base station needed a data (temperature and moisture value) from a particular area, it sent the address of the cluster head in that area. Now the addressed cluster head switched from its idle state to active state. Then the cluster head sent a request to its members by sending the address of the member nodes based on the TDMA schedule. i.e. only one node is addressed in a particular time slot. Each node sent data during their allocated time slot. The communication is similar to that in the single – hop method discussed above. The cluster head node kept its radio ON to receive all the data from the member nodes. When all the data are received, the cluster head performed the aggregation to compress the data. This data is sent to the base station. This process is repeated in all the clusters. After a certain time the next round began with each cluster assigned with a new cluster head. The new cluster head is selected based on the energy. Using this algorithm we could increase our range of the coverage area and reduce the energy consumption of each sensor nodes.

CONCLUSION

Wireless sensor networks (WSNs) find wide applications in environmental monitoring. MAC protocols play a vital role in controlling the energy consumption in a WSN. It tells the network when and how to access the medium. We discussed the basic concepts and application of WSN in agriculture.

REFERENCES

- [1] J. Tooper, M.C. Vuran, Mobile Data Harvesting in Wireless Underground Sensor Networks, in: Proc. of SECON '12, Seoul, Korea, 2012.
- [2] X. Dong, M.C. Vuran, A channel model for wireless underground sensor networks using lateral waves, in: IEEE Globecom '11, Houston, TX, 2011.
- [3] Z. Sun, I.F. Akyildiz, G. Hancke, Dynamic connectivity in wireless underground sensor networks, IEEE Transactions on Wireless Communications, 10 (12) (2011), pp. 4334–4344.
- [4] A.R. Silva, M.C. Vuran, Communication with aboveground devices in wireless underground sensor networks: an empirical study, in: Proc. IEEE ICC '10, Cape Town, South Africa, 2010.
- [5] S. Irmak, W.R. Rathje, Plant growth and yield as affected by wet soil conditions due to flooding or over-irrigation, University of Nebraska-Lincoln Extension NebGuide, G1904, 2008.
- [6] L. Li, M.C. Vuran, I.F. Akyildiz, Characteristics of underground channel for wireless underground sensor networks, in: Proc. Med-Hoc-Net 07, Corfu, Greece, 2007.
- [7] I.F. Akyildiz, E.P. Stuntebeck, Wireless underground sensor networks: research challenges, Ad Hoc Networks Journal (Elsevier), 4 (2006), pp. 669–686.
- [8] Van Hoesel, L.F.W., Nieberg, T., Kip, H.J., Havinga, P.J.M., 2004. Advantages of a TDMA based energy-efficient, self-organizing MAC protocol for WSNs. In: IEEE 59th Vehicular Technology Conference, 2004. VTC 2004 – spring, 2004.
- [9] Ye, Wei., Heidemann, J., Medium Access Control in Wireless Sensor Networks. USC/ISI Technical Report ISI-TR-580 (OCTOBER. 2003.
- [10] Ye, Wei., Heidemann, J., Estrin, D., An energy-efficient MAC protocol for WSN. In: Proceedings of the 21st International Annual Joint Conference of the INFOCOM 2002, New York, NY, USA (June).